



INSTALLATION INSTRUCTIONS

Accessory

CB RADIO KIT
P/N 08E95-MCA-102

Application

GL1800

Publications No.

Issue Date

February 2007

Honda Dealer: Please give a copy of this instruction to your customer.

PARTS LIST

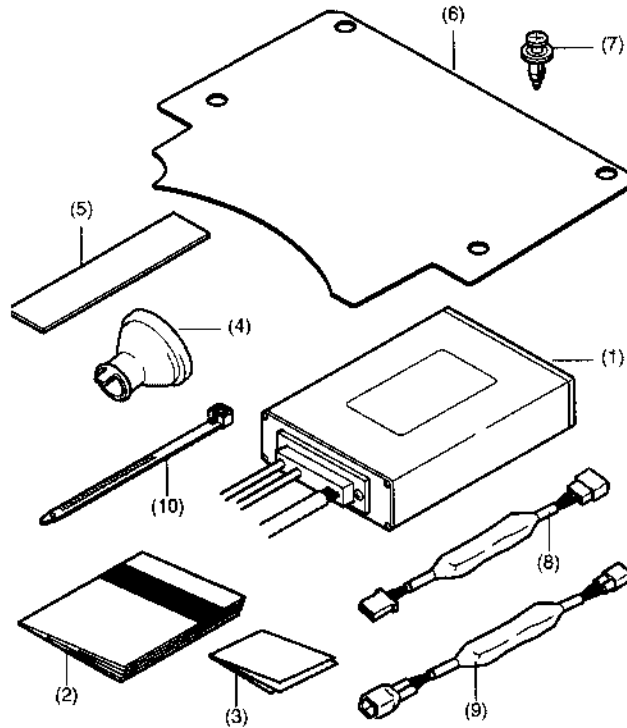

No.	Description	Qty
(1)	CB radio	1
(2)	Owner's Manual	1
(3)	FCC Rule Book	1
(4)	Grommet	1
(5)	Cushion tape	4
(6)	Plate	1
(7)	Rivet	4
(8)	Capacitor (2P)	2
(9)	Capacitor (2P waterproof)	1
(10)	Wire tie	3

TOOLS AND SUPPLIES REQUIRED

Phillips ® screwdriver
 Electric drill motor
 Drill bit (7, 10 mm)
 Hole saw (28 mm)
 Scissors
 Wood block
 Isopropyl alcohol
 Torque wrench

USE AND CARE INFORMATION

The combined weight of the cargo and accessories must not exceed the maximum weight capacity of the trunk:

CB Radio Kit	1.6 lbs (0.7 kg)
--------------	------------------

INSTALLATION

NOTE:

- These instructions are for installation of the CB radio. For operation of the CB radio, refer to the Owner's Manual and FCC Rule Book furnished with the CB radio.
- Install the antenna which is sold separately between the installation of the rear trunk and the routing of the wire harness.
- It is not necessary to drill four 7 mm holes and install the plate when you are also installing the CD changer.

1. Refer to the Service Manual to remove the right and left side covers and disconnect the negative terminal from the battery.

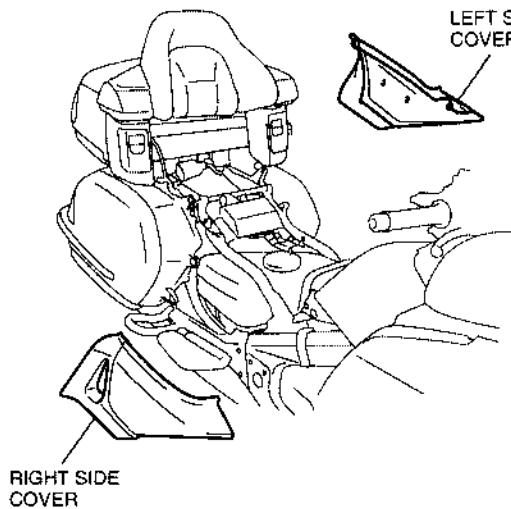
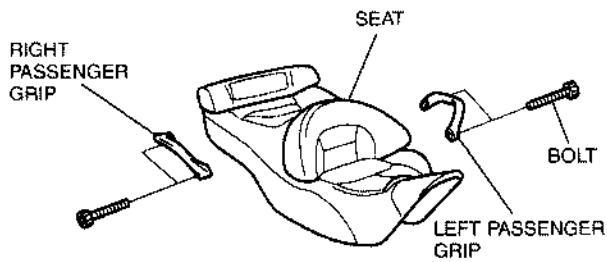

2. Remove the meter panel from the motorcycle as indicated in the Service Manual.

- Up to '05 model year -

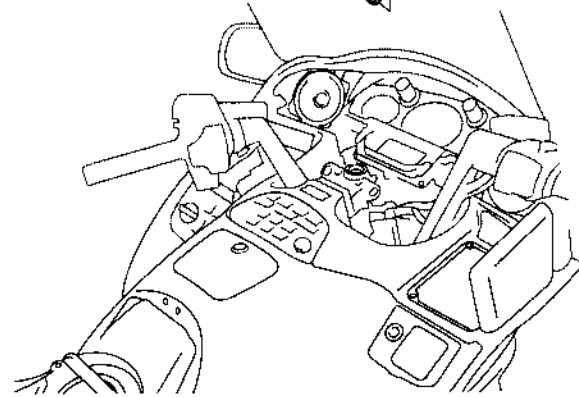
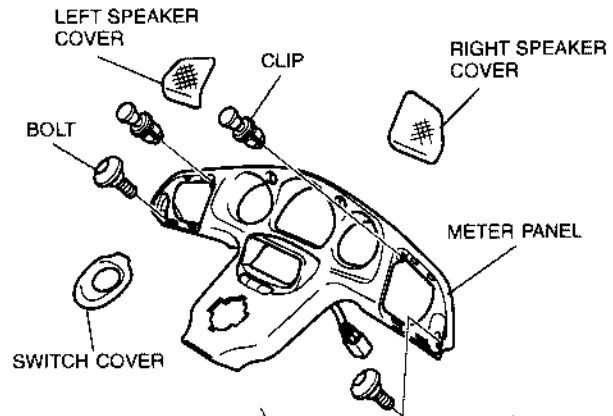

- From '06 model year -

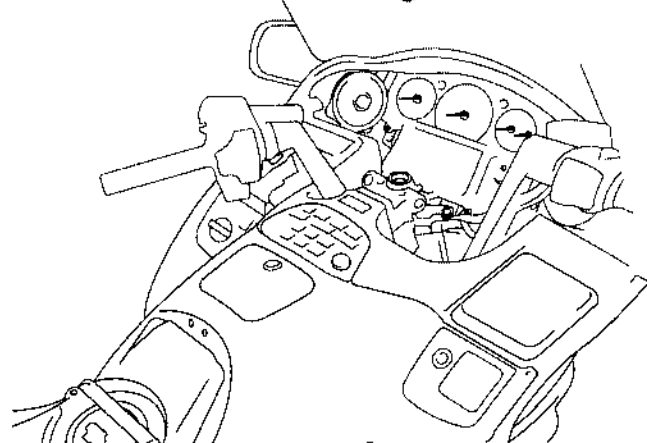
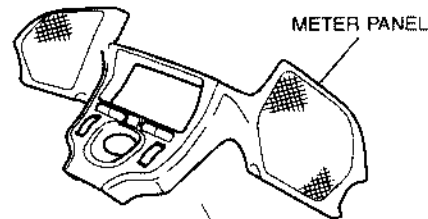

- Airbag Type -

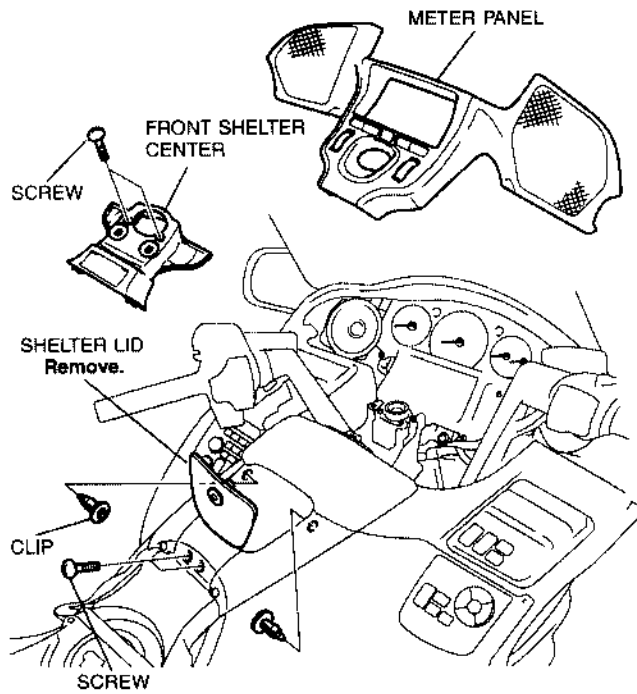

3. Remove the parts from the motorcycle as indicated in the Service Manual.

- Up to '05 model year -

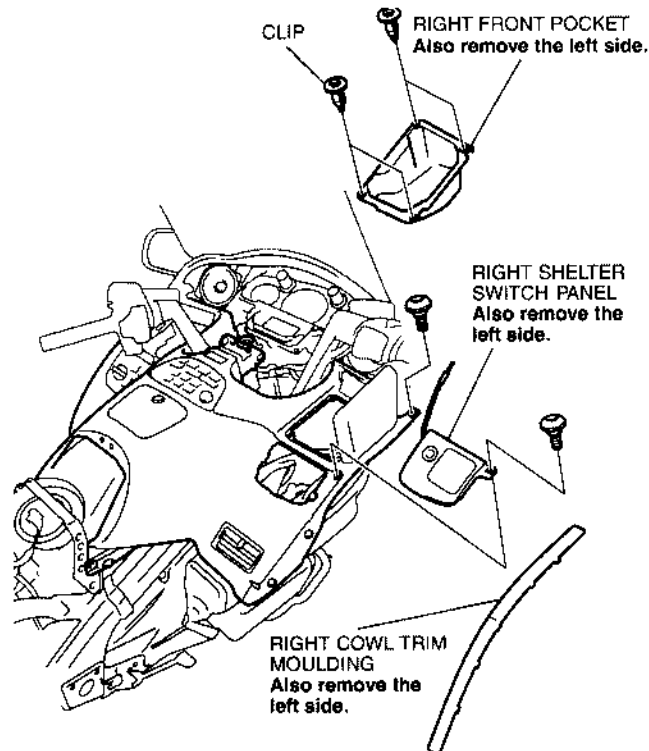

- From '06 model year -

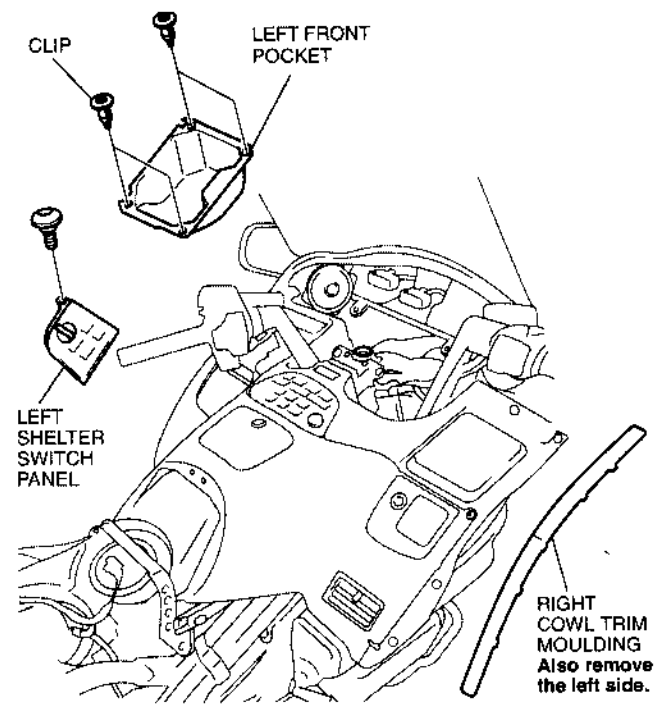

- Airbag Type -

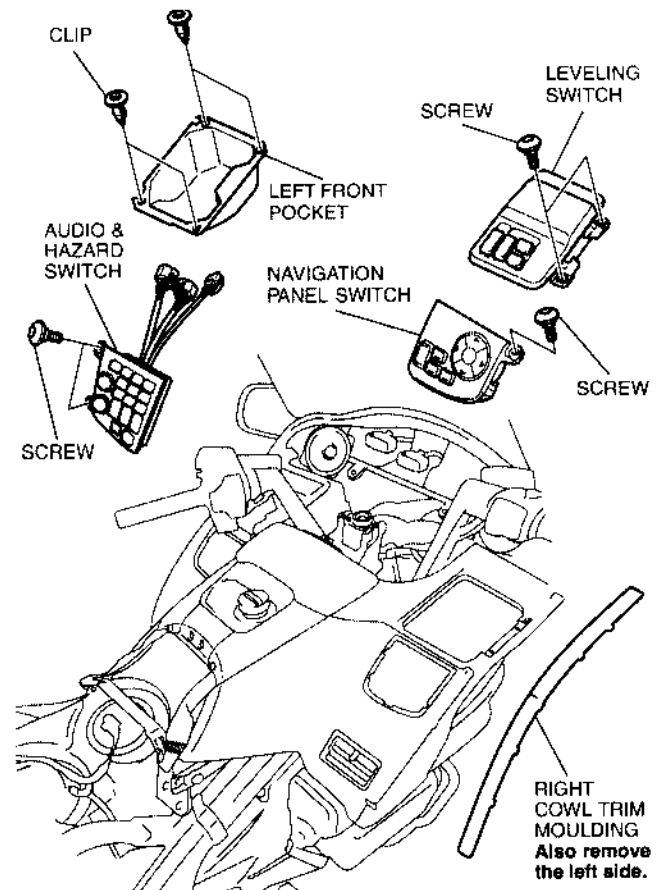

4. Remove the shelter from the motorcycle as indicated in the Service Manual.

- Up to '05 model year -

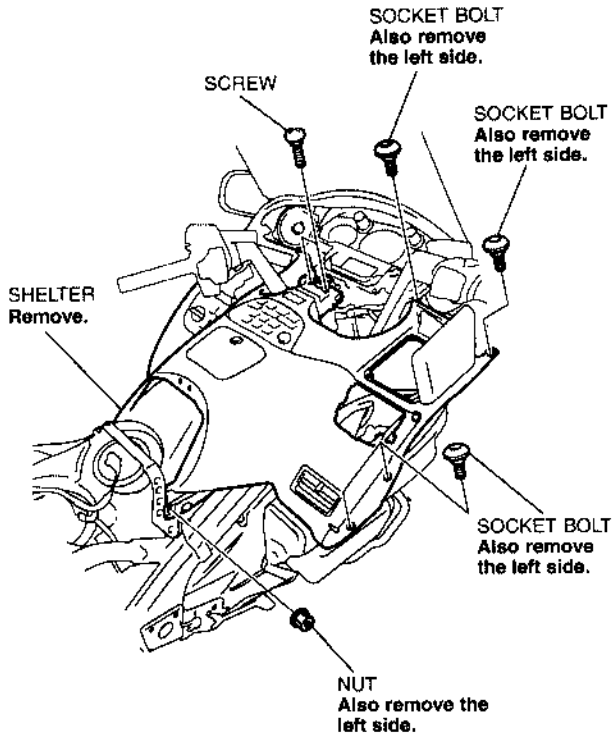

- From '06 model year -

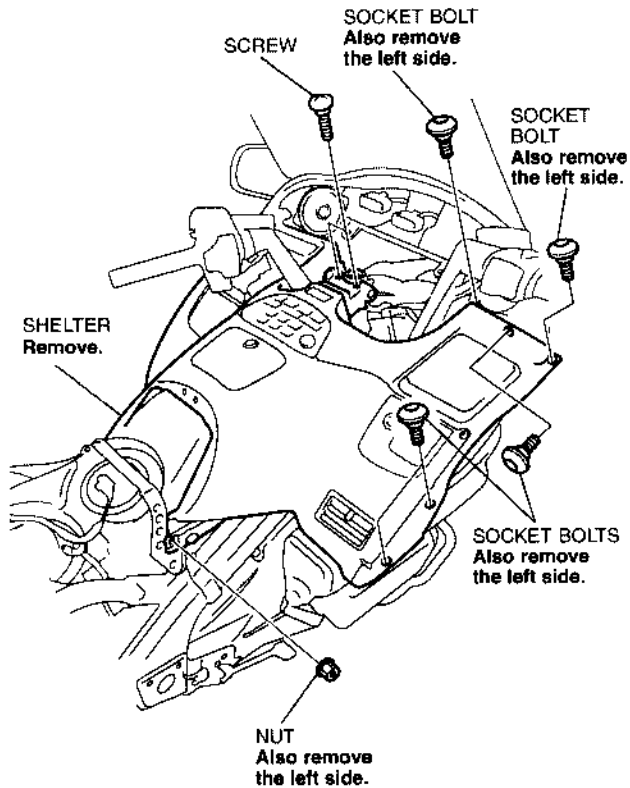

- Airbag Type -

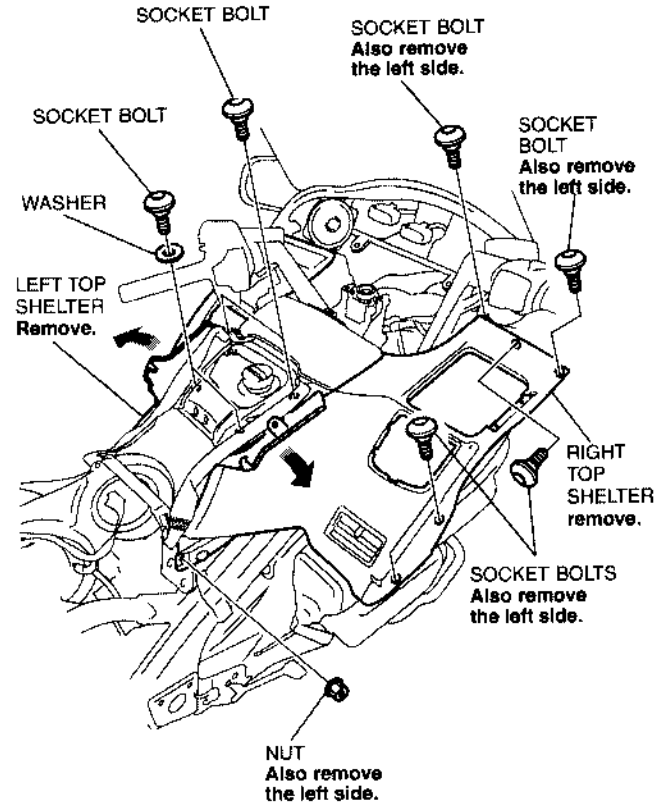

5. Remove the rear trunk as indicated in the Service Manual.

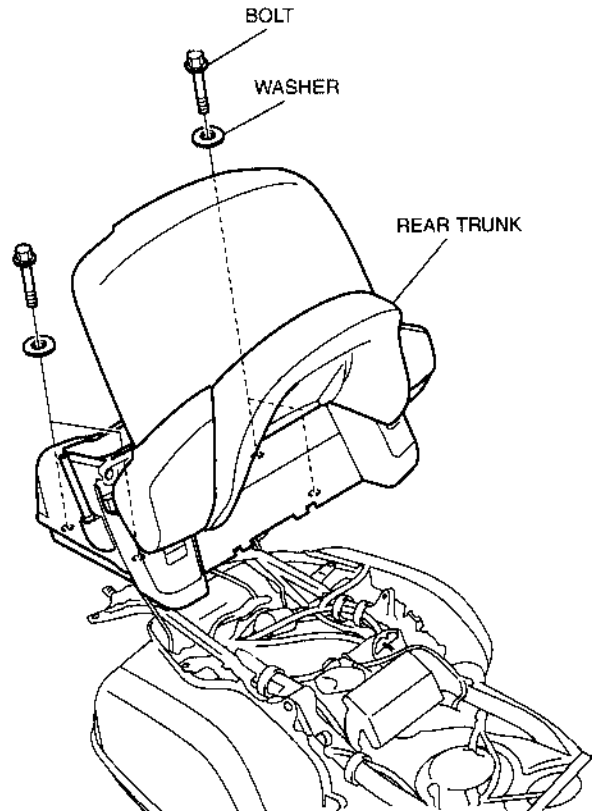

6. Locate the mark on the back of the trunk. Using an electric drill motor and hole saw, drill a 28 mm hole through the mark as shown.

- Remove any burrs from the edge of the hole.

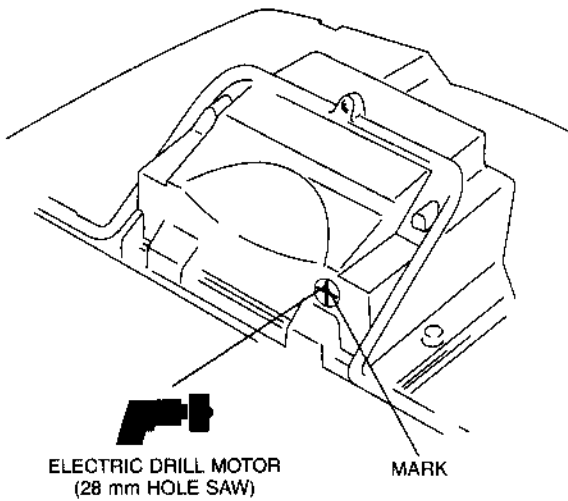

7. Inside the rear trunk, locate the four marks. Drill a hole through each mark using an electric drill motor and 7 mm drill bit.

- Do not drill the 7 mm holes if you are installing the CD changer.
- Remove any burrs from the edge of the hole.

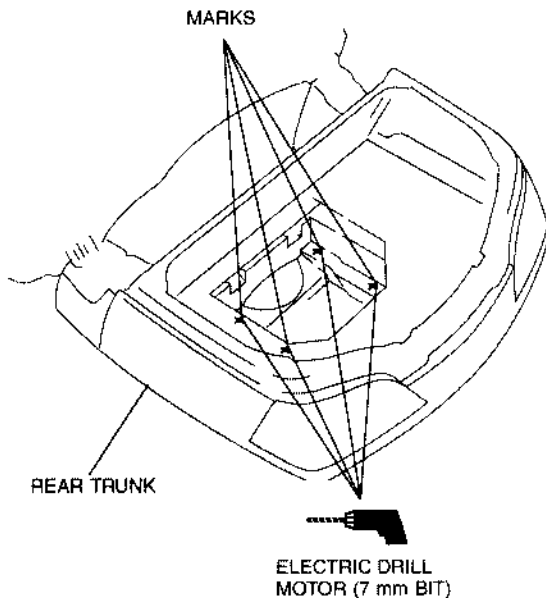

8. Attach the cushion tapes on the CB radio as shown.

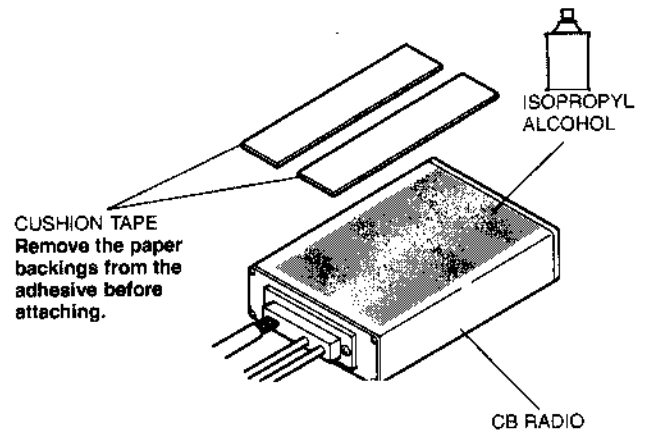

9. Install the CB radio in the rear trunk.

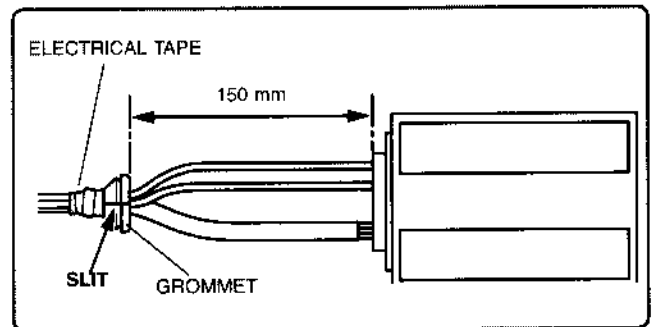
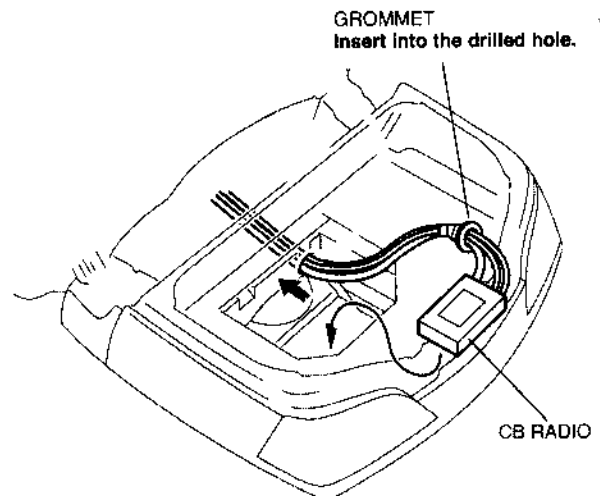

10. Install the plate on the rear trunk if you are installing the CD changer.

11. Reinstall the trunk lid being careful not to pinch the wire harness.

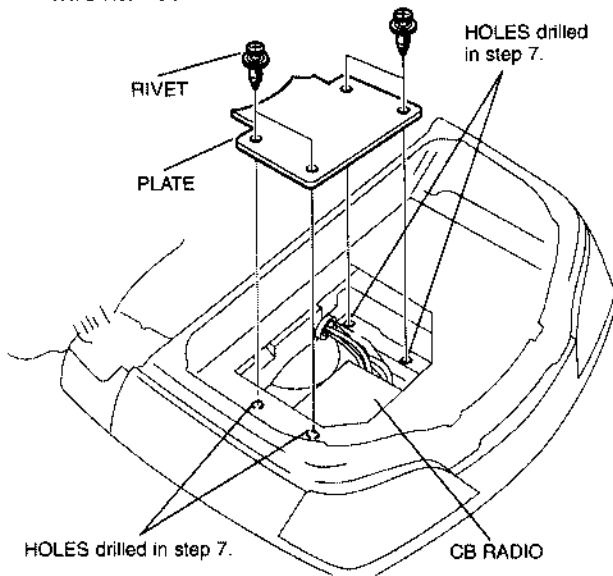

12. Remove the right and left duct as shown.
 • This step is for airbag type only.

Right side

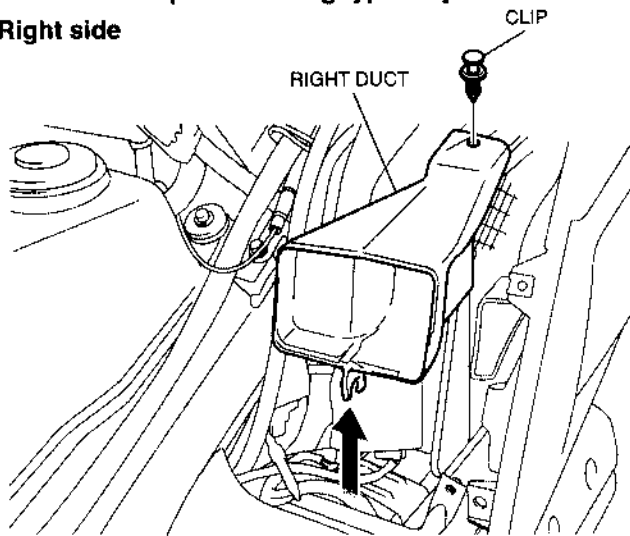

Left side

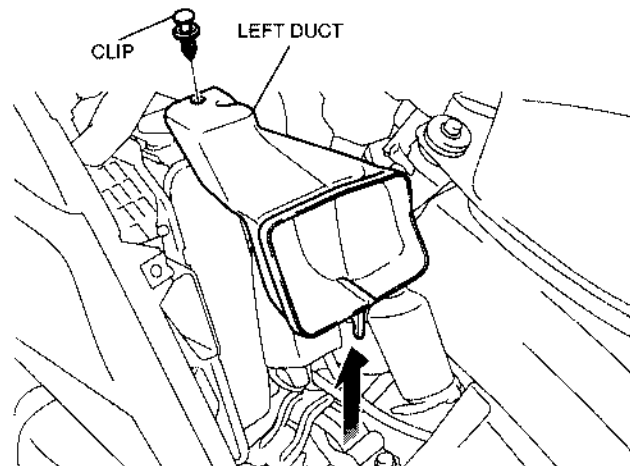

13. Route the CB radio harness as shown.

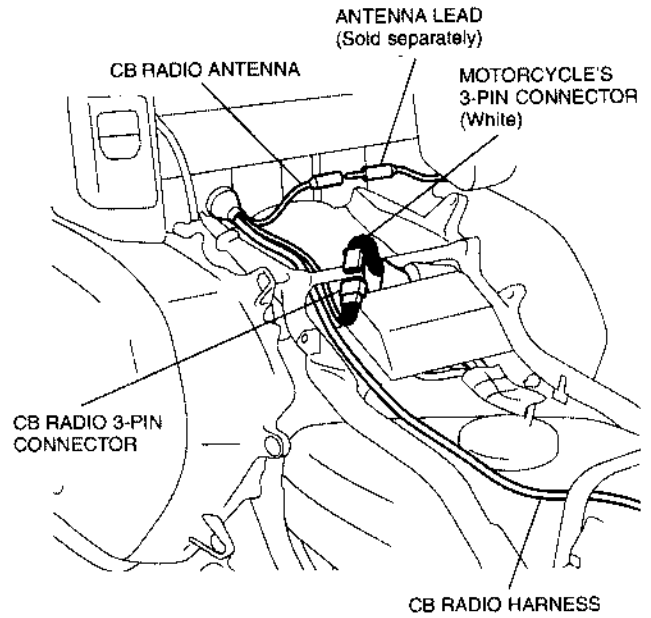

MOTORCYCLE'S
13-PIN CONNECTOR
(White)(unused)

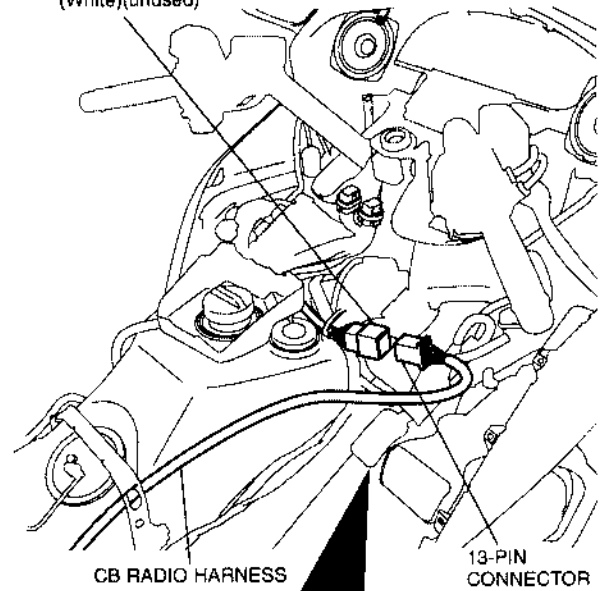

Airbag Type (right side)

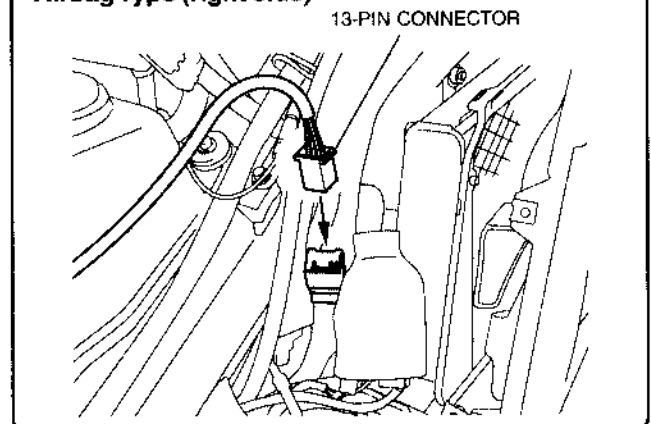

14. Connect the capacitor as shown.

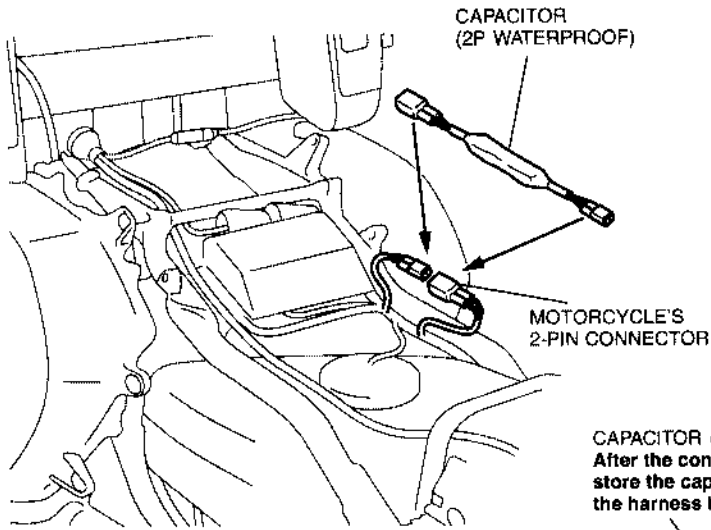

CAPACITOR (2P)
After the connection,
store the capacitor in
the harness boot.

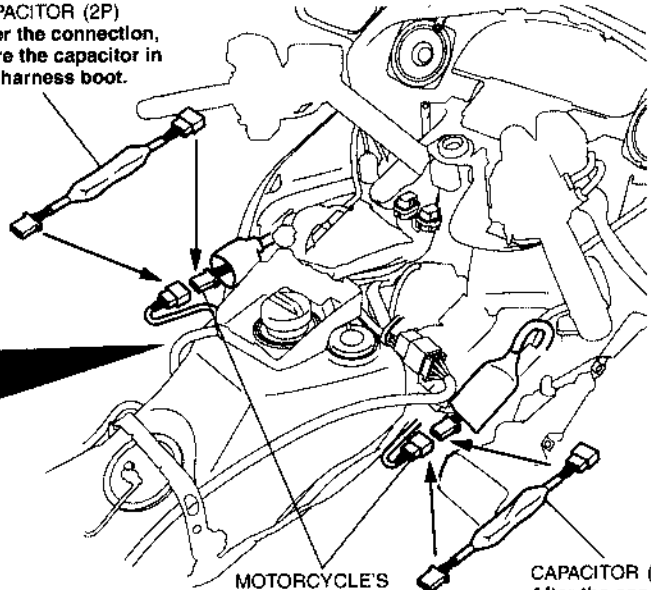

Airbag Type (left side)

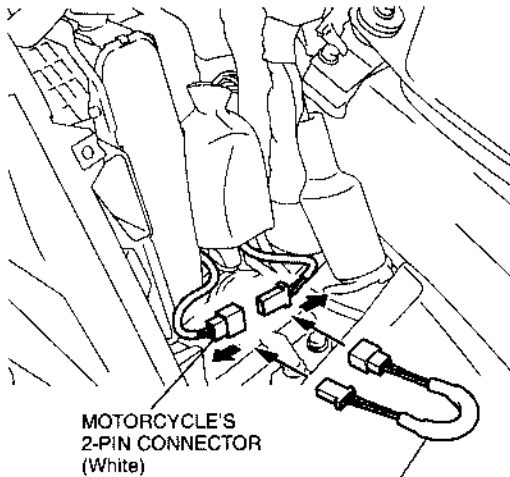

Airbag Type (right side)

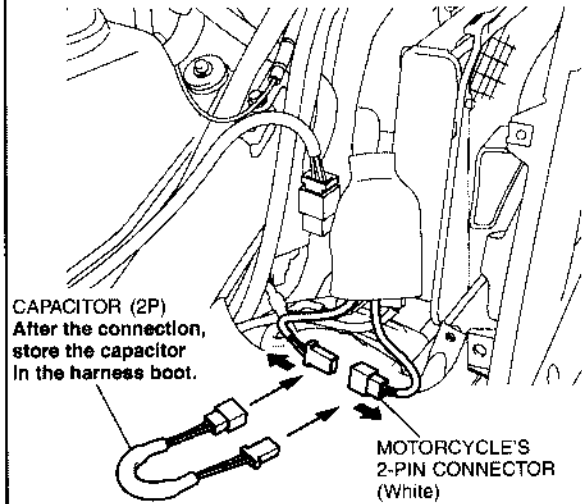

15. Cut the two cushion tapes into halves.

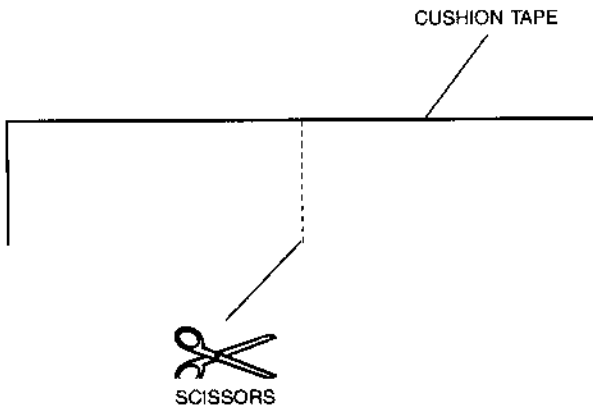

16. Secure the wire harness with the wire ties and cushion tapes in the areas shown.

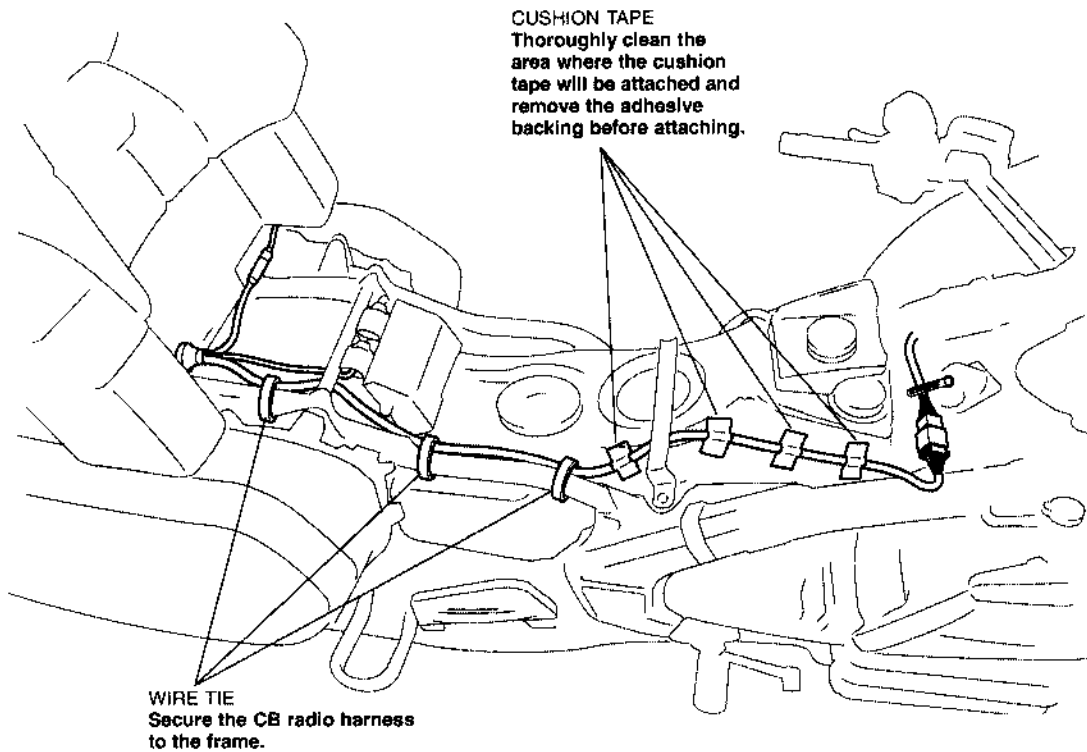

17. Reinstall the fuel tank cover, meter panel, side moldings and side covers being careful not to pinch the wire harness.
18. Reconnect the negative cable to the battery.
19. Reinstall the seat in the reverse order of removal.