



INSTALLATION INSTRUCTIONS

Accessory
CHROME FRONT DISC COVERS
P/N 08P54-MCA-100

Application
GL1800

Publications No.
Issue Date
September 2000

Honda Dealer: Please give a copy of this instruction to your customer.

PARTS LIST

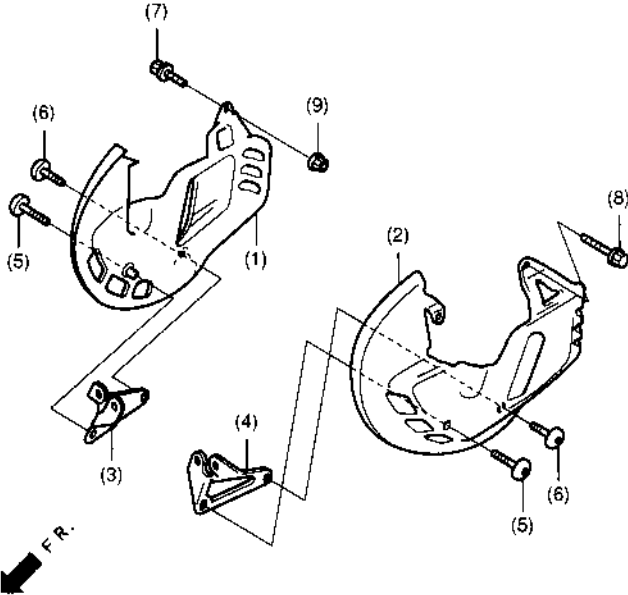

No.	Description	Q'ty
(1)	Right front disc cover	1
(2)	Left front disc cover	1
(3)	Right stay	1
(4)	Left stay	1
(5)	6 mm Socket bolt (long)	2
(6)	6 mm Socket bolt (short)	2
(7)	6 mm SH flange bolt (short)	1
(8)	6 mm SH flange bolt (long)	1
(9)	6 mm Flange nut	1

TOOLS REQUIRED

- Socket (8 mm)
- Ratchet
- Box-end Wrench (10 mm)
- Hex wrench (5 mm)

TORQUE CHART

Be sure to tighten all bolts and nuts to their specified torques.

Item	N·m	kgf·m	lbf·ft
6mm SH flange bolt	9	0.9	6.5
6mm Socket bolt	10	1.0	7
6mm Flange nut	12	1.2	9

INSTALLATION

1. Remove the front fender.

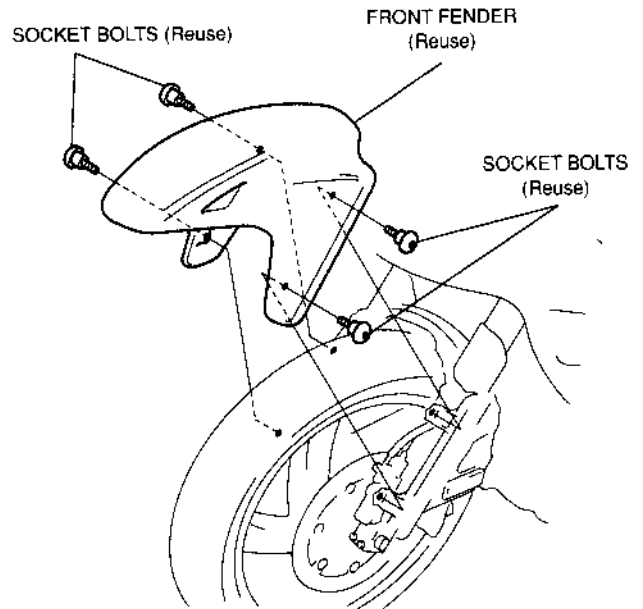

2. Remove the left front fender cover.

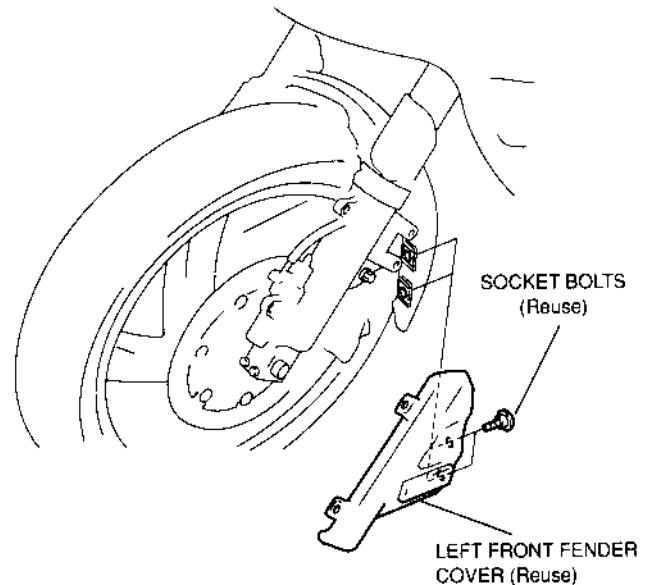

3. Remove the right front fender cover.

4. Remove the bolts.

BOLT (Save)
ABS model only.

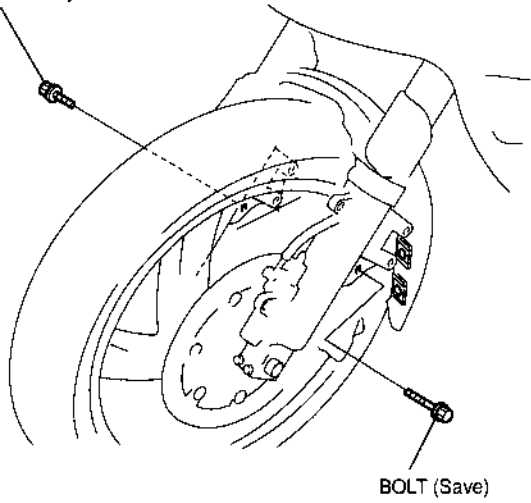

5. Install the left stay as shown.
6. Install the right stay in the same manner.
• **Install the stays one by one.**

LEFT FRONT FORK

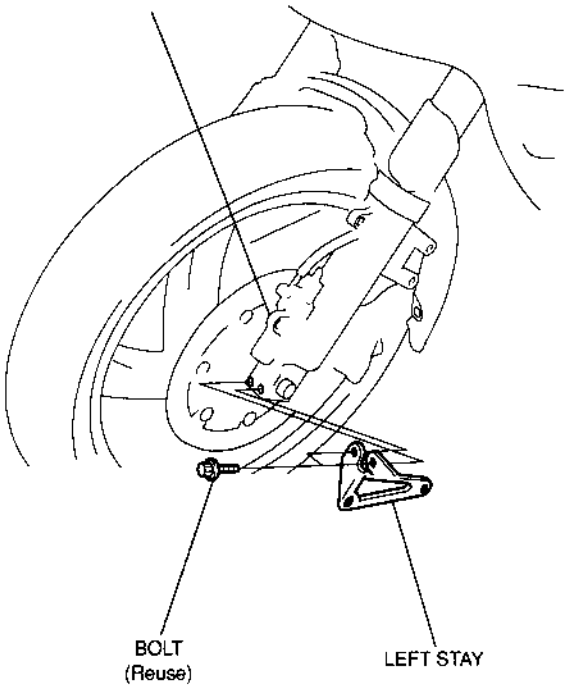

7. Temporarily install the left front disc cover as shown.
8. Temporarily install the right front disc cover in the same manner.

6 mm FLANGE NUT
Only on the right side.
Not required for ABS model.

6 mm SH FLANGE BOLT (long)
Use the 6 mm SH flange bolt
(short) for the right front disc
cover.

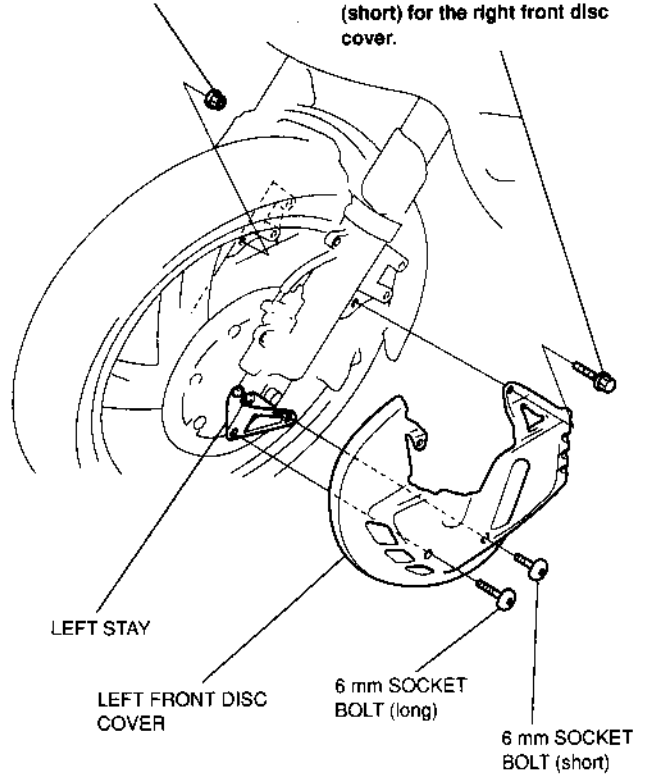

9. Reinstall the front fender and front fender covers in the reverse order of removal.
10. Tighten all bolts and nuts to the specified torques.